

**Serial ATA Host Controller STR4GX  
VHDL IP**

**Product Brief**

Feb 10 – Ver. 1.0

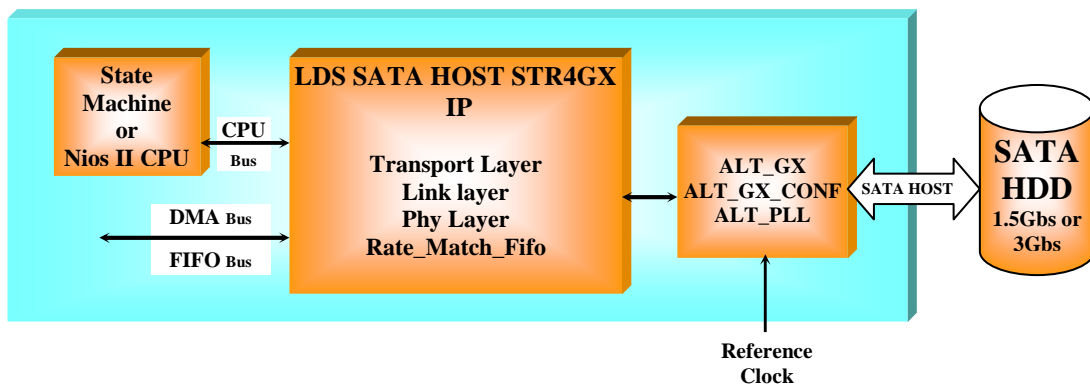

**Features**

The LDS\_SATA\_HOST\_STR4GX IP incorporates the Transport layer, the Link layer, the PHY layer and the Rate Match FIFO on a ALTERA Stratix IV GX FPGA. The LDS\_SATA\_HOST\_STR4GX IP is compliant with Serial ATA II specification and signaling rate is 1.5Gbps and scalable 3Gbs. The LDS\_SATA\_HOST\_STR4GX IP is fully synchronous with system frequency (Clock\_sys) at 37.5MHz in case of 1.5Gbps speed selection and 75MHz in case of 3Gbs speed selection. The VHDL source code format is available for ease of customization. The customization can be done by Logic Design Solutions and **DO254** documentation is available on request.

**Rate Match FIFO**

- Manage SATA reference frequency difference between the FPGA and the Disk

**Physical Layer features**

- Detect and generate OOB sequence
- Detect the K28.5 comma character and provides a 16 bit parallel output
- Power management mode handled by state machine (shared between Phy and Link layer)
- Provides error indication to upper layers
- 8b/10b encoding and decoding in ALTERA Stratix IV ALT\_GX Macro
- Manages 1.5Gbs or 3Gbs data rate

**Link Layer features**

- Scrambling of tx data and descrambling of rx data
- CRC 32 generation and check
- Report transmission status and error to Transport Layer
- Enable BIST loopback and pattern generation modes
- Auto inserted hold primitive to avoid FIFO overflow and underflow
- Partial and slumber power management modes
- The interface between the link layer and the transport layer is 32-bit wide

## Transport Layer features

- 48-bits sector address
- Programmed IO (PIO) and DMA modes
- Support BIST FIS transmission and reception
- Automatic error FIS retry capability
- Implement Shadow Registers and SATA SuperSet registers
- Simple synchronous CPU and DMA Interface for data transfers including DMA hold-off capability
- DMA interface can be connected easily to memory space or FIFOs
- Support DMA Abort primitive

## Application Example

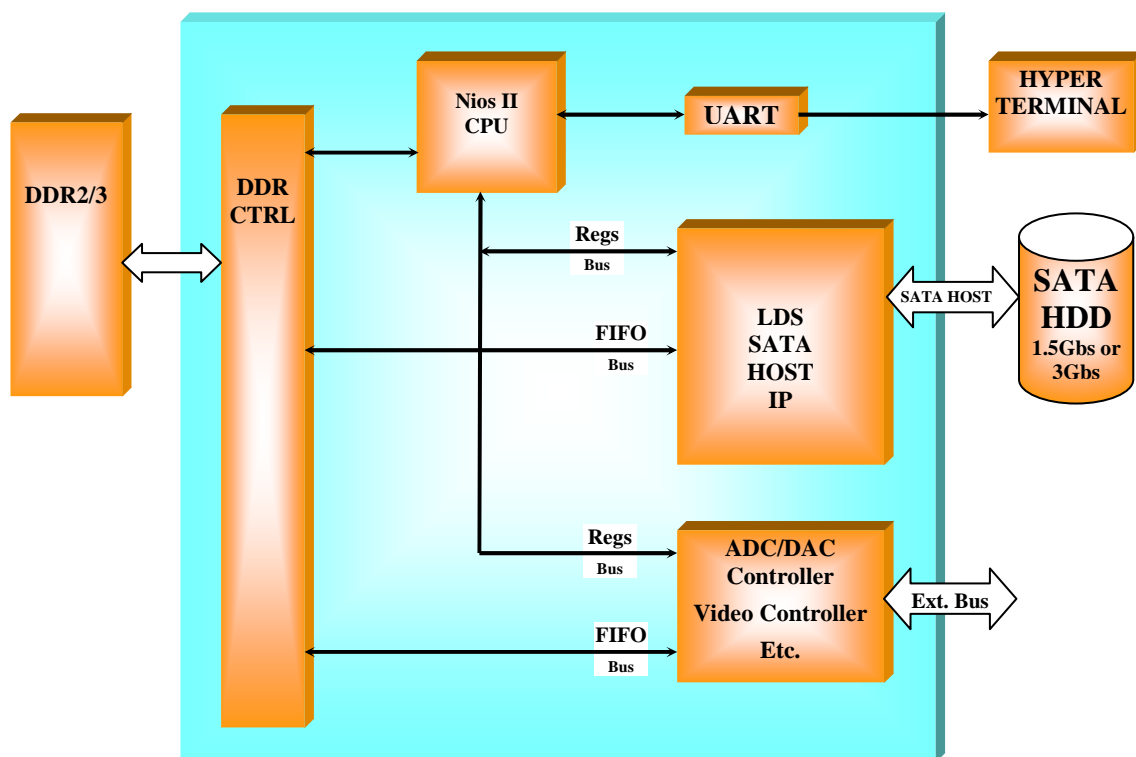

## Verification

The LDS\_SATA\_HOST\_STR4GX IP has been validated on the ALTERA Stratix IV GX development board (DK-SI-4SGX230N) and several hard drives.

## Performance

Example : Intel X25 SSD 3Gbs => 1Gbytes transfer at 200MB/s in sequential read and write – DMA transfer of 128 sectors.

## Design Package

<b>Device Family</b>	<b>ALTERA Stratix IV GX FPGA – speed grade : Lowest</b>
<b>ALUT used</b>	2600
<b>Logic utilization</b>	3300
<b>Total register</b>	2250
<b>Total LAB</b>	218
<b>M9K Blocks</b>	2
<b>Package file</b>	<b>Synthesis Netlist :</b> Data Sheet, Quartus project Description and Constraint File
	<b>VHDL Source code :</b> Data Sheet , Quartus project Description and Constraint File.
<b>Design Tool Used</b>	ALTERA QUARTUS II v9.1 SP2. VHDL ModelSim simulation tool from ModelTech.
<b>Support</b>	Support provided by Logic Design Solutions 1 year e-mail and telephone support from Logic Design Solutions included in the IP price. Support does not cover User IP modifications. Maintenance Contracts available.

## General Description

The LDS\_SATA\_HOST\_STAR4GX IP implements a single-chip synchronous Serial-ATA macro which can be used to interface between memory and Serial-ATA devices. The LDS\_SATA\_HOST\_STR4GX IP is available only on ALTERA Stratix IV GX FPGA.

This IP can be customized according to specific needs (application-specific requirement). Any other pre-designed functions can be integrated into the FPGA. FPGA density and I/O requirements can be defined according to customer specification.

## Recommended Design Experience

Designers should be familiar with Serial ATA, VHDL, synthesis tools, FPGA Place and Route data flow and VHDL simulation software. Experience with microprocessor is recommended. The IP can be easily integrated into hierarchical VHDL designs.

## Ordering Information

To purchase or make further inquiries about this, or any other Logic Design Solutions products and services, contact Logic Design Solutions in France.

Logic Design Solutions also offers IP integration and design services on FPGA.

Logic Design Solutions IPs are purchased under a License Agreement, copies of which are available on request.

Logic Design Solutions reserves the right to make changes to these specifications at any time, without notice.

**All trademarks, registered trademarks, or service marks are the property of their respective owners.**

## Available Support Products

Support products available from Logic Design Solutions.

## Related Information

### Logic Design Solutions

106 Boulevard de la Résistance

93460 Gournay sur Marne – France.

Phone : +33 (0) 1 45 92 24 47

Fax : +33 (0) 1 45 92 22 10

E-mail : [info@logic-design-solutions.com](mailto:info@logic-design-solutions.com)

WEB: <http://www.logic-design-solutions.com>

### Distributor in Taiwan :

Avant Technology, Inc.

Address: 5F-1, No.83, Sec.2, Gongdaowu Rd, Hsinchu, Taiwan ([Click here for map](#))

Phone : (03)516-0128

Fax : (03)516-0166

Contact: Yao-Chang Chang

Sales : [sales@avant-tek.com](mailto:sales@avant-tek.com)

### Distributor in China :

Avant Technology, Inc.

Address : Room B804 No.668 Beijing East RD., Shanghai ([www.avant-tek.com](http://www.avant-tek.com))

ZIP Code 200001

Phone : 86-21-5308-5991

Contact : Yao-Chang Chang

Email : [sales@avant-tek.com](mailto:sales@avant-tek.com)